

MGX10

Benchtop laser thickness gauge.

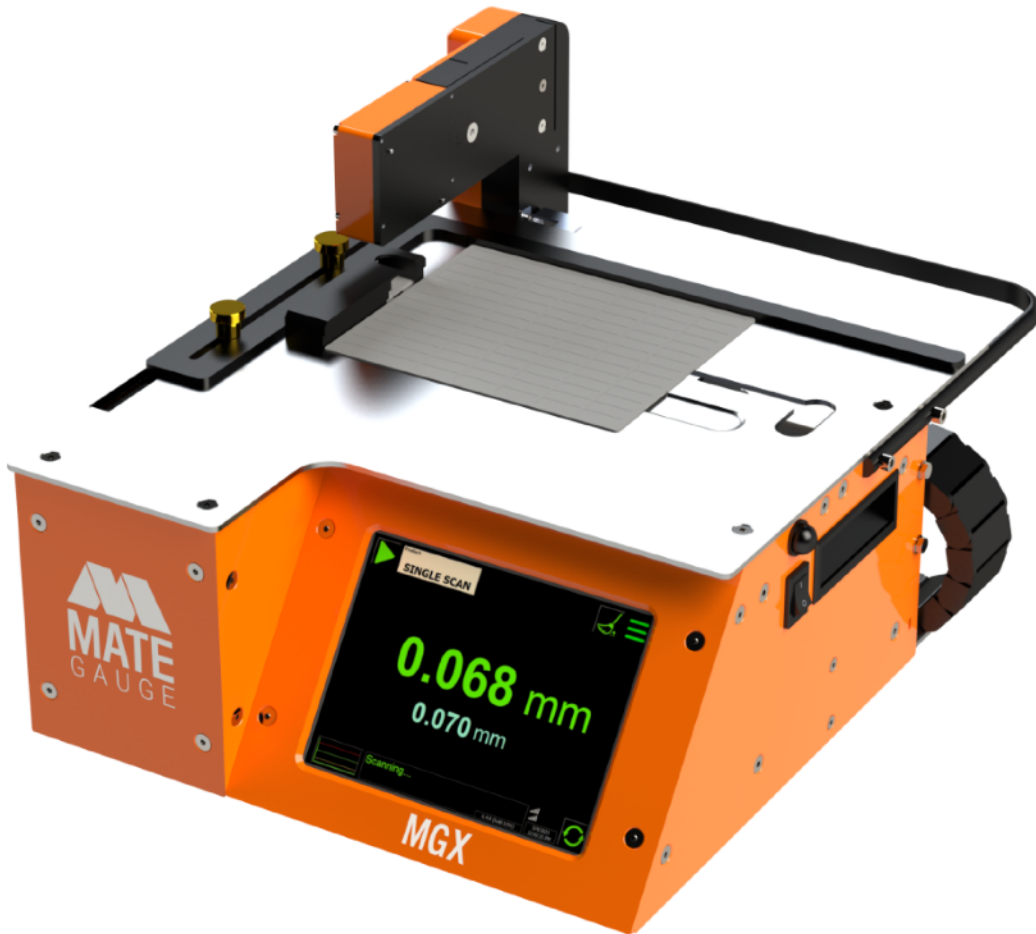

PRECISION MEETS PORTABILITY — MEASURE WITH EASE



Scan for digital
download.

+1 613-287-0171
mategauge.com



LASER TRIANGULATION TECHNOLOGY FOR NON-CONTACT THICKNESS MEASUREMENT

The system uses two laser sensors – one above and one below the material – to measure thickness along a straight path. The sensors are mounted on actuator-powered arms that traverse the entire width of the material. The laser travels along the length of the table passing through the slot in the tabletop. The gauge measures thickness at a rate of 1000 to 5000 samples per second.

- ✓ Flexible Installation: easily set up your gauge in any suitable location.
- ✓ Alert system for sensor dirt accumulation
- ✓ Automatic Thickness Reference (TR) check compensates for thermal expansion
- ✓ Optional weight scale add-on
- ✓ Quick cleaning process to minimize production disruption
- ✓ Easy calibration every 3 months using NIST-traceable master block

Optional weight scale add-on



mgOS SOFTWARE - PURPOSE-BUILT FOR OPERATOR EASE

Whether you're upgrading existing systems or implementing new ones, the MGX10 integrates with your systems through PLC connection and Ethernet ports. The Mate Gauge software filters and processes the thickness waveform to extract and record measurements and key performance indicators (KPIs). Measurement results are continuously published and displayed on a touchscreen display.



Full thickness profile displayed

- Sample thickness measurement
- Sample width measurement



Automation with PLC

- Automatic changes in thickness, settings, and scan data.



Data Visualization

- Real-time data visualizations designed for operator ease
- Touchscreen display



PDF and .CSV reporting

- Data file downloads for offline analysis
- Trend tracking over run-time



Custom App

- Virtual Micrometer settings
- Ability to set thickness KPIs



Alerts

- Configurable alerts based on target specifications

MGX10 SCHEMATICS

The following schematics illustrate the standard configuration of your Mate Gauge. This configuration includes the essential components and layout designed for general applications.

Different applications and sensors types require specific adjustments to the Mate Gauge configuration. We are committed to providing solutions tailored to your specific measurement needs.

Contact Us

System Drawings

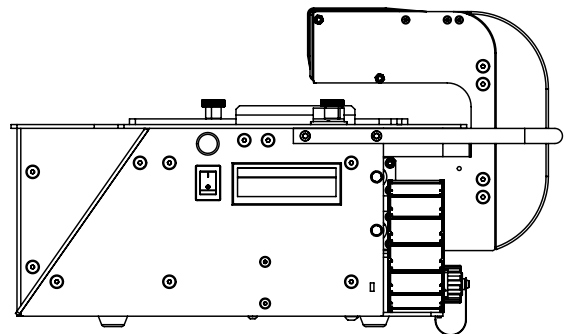
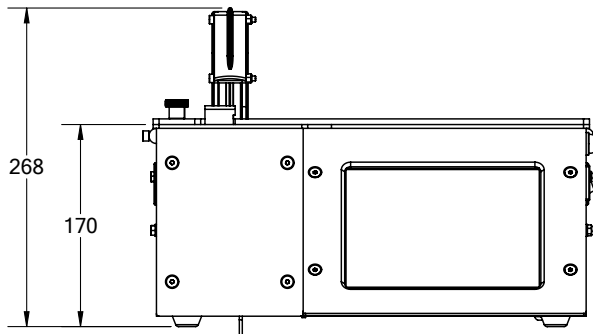
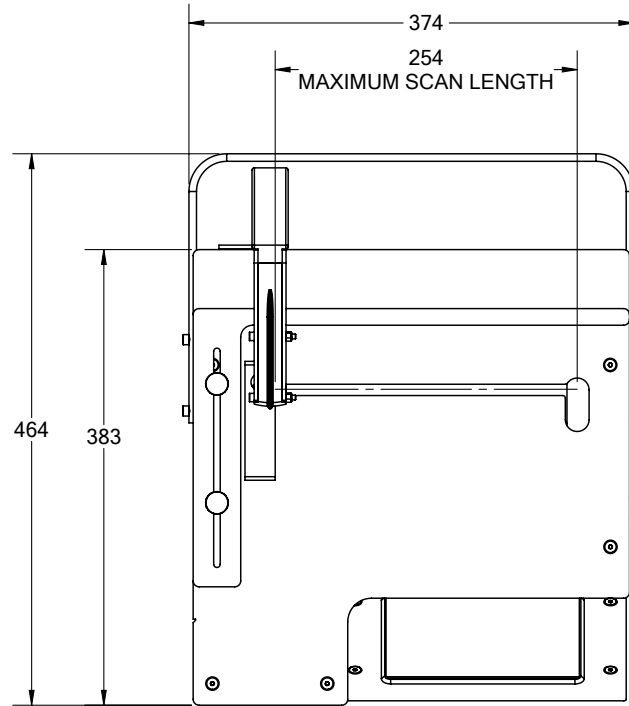

WHAT IS INSIDE THE BOX?

The benchtop system is ready to run out-of-the-box. It includes two laser sensors, c-frame, scanning belt drive system, NIST traceable calibration reference block, a built-in touchscreen and measurement tray.

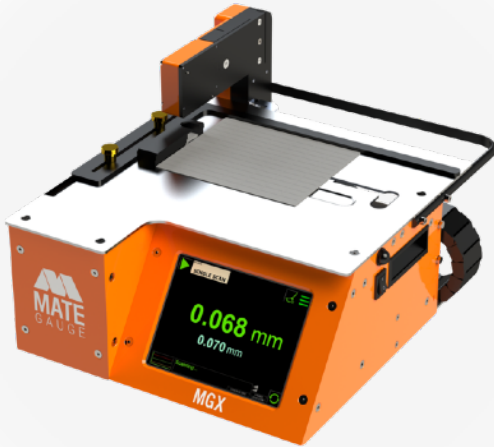

Laser Gauge



Power Cable



N.I.S.T. Traceable Calibration Block



Calibration Block Holder

MGX10 TECHNICAL SPECIFICATIONS

THICKNESS MEASUREMENT DETAILS

Resolution	0.5 μm	[0.00002 in]
Accuracy (typical)	2 μm	[0.00008 in]
Stroke	254 mm	[10 in]
Scanning Speed	150 mm/sec	[6 in/sec]
Thickness Range	0 to 8 mm	[0 to 0.32 in]
Measurement Frequency	1 to 5 kHz	

SUPPLY REQUIREMENTS

Power	1A @ 115V, 0.5A @230V, 50/60Hz
-------	--------------------------------

WEIGHT

Complete Assembly	10 kg	[22 lbs]
-------------------	-------	----------

PHYSICAL DIMENSIONS

Main Housing	355x457x254 mm	[14x18x10 in]
--------------	----------------	---------------

ENVIRONMENTAL REQUIREMENTS

Operating Temperature	5 °C to 45 °C	[41 °F to 113 °F]
Humidity	< 90%	

SUPPORT AND SERVICES

Mate Gauge provides comprehensive support services to ensure optimal performance of your MGX10 system. From initial setup to ongoing maintenance, our team is committed to your success.



Try before you buy with our trial program.



Post-purchase support with on-call technicians



Product setup guidance and training

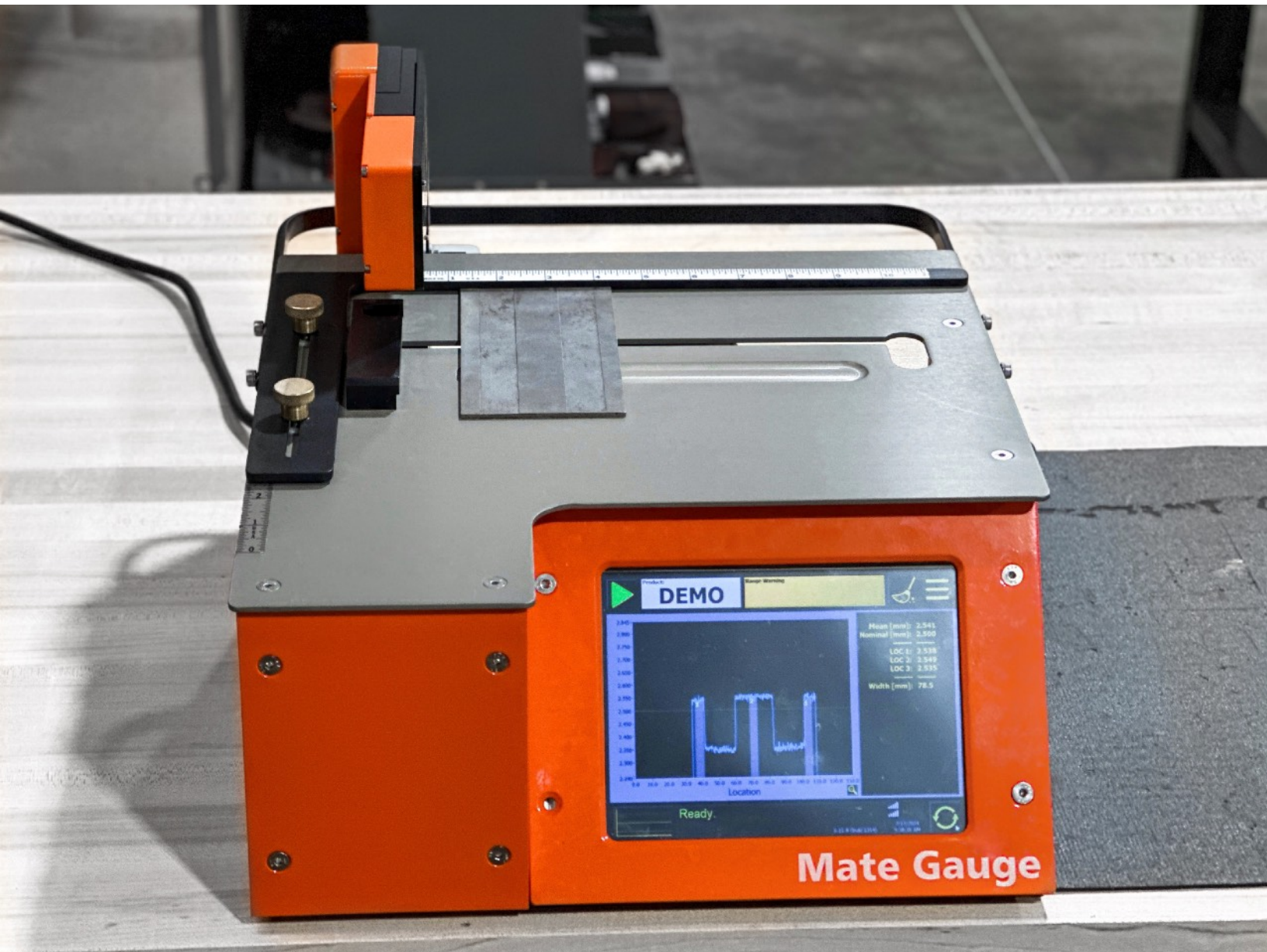

Beyond measure.

© 2024 Mate Gauge